

# SUN



**ELECTROMECHANICAL MOTORS FOR  
SLIDING GATES WITH INTERGRATED  
NIGHT LIGHT SYSTEM**



# SUN UP TO 1100 KG, 24 VDC WITH INTEGRATED NIGHT LIGHT SYSTEM



Stylish design screwless at sight

Extremely silent mechanics

Built-in LED light

High technological materials resistant to weather conditions

**SUN FAST:** Opening speed up to 40 cm/sec

## NIGHT LIGHT SYSTEM

Concept that combines the comfort of an automatic gate with the use of LED lighting to illuminate your entrance over night

- + **SAFETY** Ease the night vision
- + **COMFORT** Defines the driveway passage during the night Allows
- + **SAVING** lower power consumption

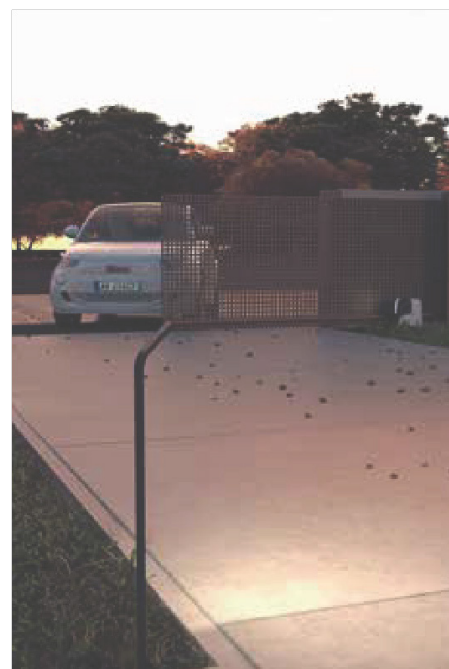
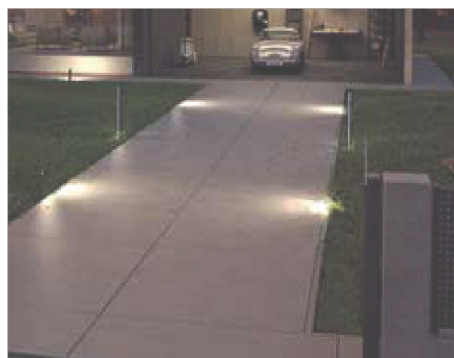

## MODELS

CODE	DESCRIPTION
<b>SUN5024F</b>	For sliding gates up to 500 Kg, 24 Vdc fast motor, control unit 14A with slowdown and magnetic limit switch
<b>SUN11024</b>	For sliding gates up to 1100 Kg, 24 Vdc motor, control unit 14A with slowdown and electric limit switch



Stylish design screwless at sight



Built-in LED light

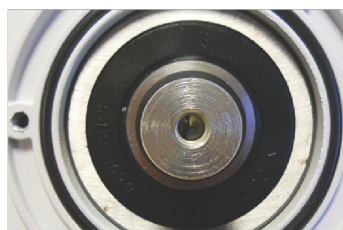

Robust gear reduction with self-standing bearing



Manufactured inhouse in KEY Italy

## TECHNICAL DATA

		SUN5024F	SUN11024
<b>MECHANICAL DATA</b>			
speed	cm/s	40*	20*
torque	Nm	23	38
working cycle	%	80	80
<b>ELECTRICAL DATA</b>			
control board		14AF 	14A
power	Vac	230	230
consumption	A	1,3	1,8
absorbed power	W	300	360
capacitor	µF	-	-
thermoprotection	°C	-	-
integrated lights		yes	yes
<b>GENERIC DATA</b>			
protection degree	IP	44	44
dimensions (L - D - H)	mm	330 - 210 - 300	
weight	kg	13,5	14,5
working temperature	°C	-20 + 55	-20 + 55
gate maximum weight	Kg	500	1100

\* variable according to the gate weight Models of 700 kg and upward are recommended for condominium installations

## DIMENSIONS

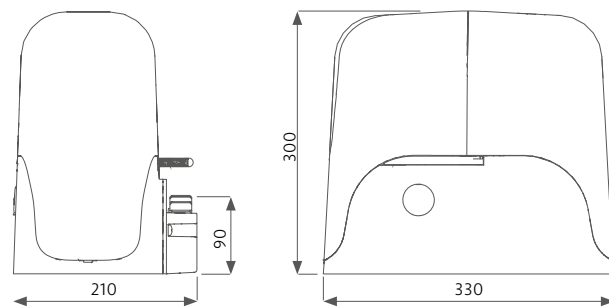

## ACCESSORIES



**RN800** \*M4 nylon rack  
L=1000 mm for gates up to 800 kg



**CREM-8** \*\* M4 zinc coated rack  
30x8 mm L=1000 mm



**CREM-12** \*\* M4 zinc coated rack  
30x12 mm L=1000 mm



**TWIN** Iinterface for master/slave function (SUN5024F, SUN7024 and SUN11024) PC 1



**KCS** Unlock kit with key



**SUB remotes** Water and dust resistant 433MHz transmitters, rolling code



**DYL** Programming module Cable length 120 cm (only 14A board)



**KUBE PRO** Wireless module for programming



**KUBE** Wireless controlling module for end user



**RX4K** 4-channel plug-in receiver, 433MHz, for 14A control unit



**KPLAY4R** Kit with 2x 4-channel 433 MHz transmitters, rolling code



**FT43** Pair of photocells for external use adjustable through 180



**FT43B** Pair of photocells for external use adjustable through 180, battery version



**FT33** Pair of photocells for external use, flush mounting



**RP25K** Reflective photocells



**ECLIPSE** Led flashing with courtesy light, crepuscular sensor and built-in antenna



**SEL-R** Wireless keypad transmitter, 433MHz



**EGKTR1** Wireless keypad transmitter, EGO series 433MHz



**TO1M** 1-channel touch transmitter, rolling code 433MHz



**RXM23Y** 2-channel universal receiver, fix or rolling code



**KBP** Kit of 1.3 Ah lead battery and battery charger



**KSOLAU** Solar kit, includes 30W panel, recharge unit in enclosure, mounting brackets and batteries



**SPLIT24V** Low Voltage box



**EG100LA** 100cm post with LED and houses accessories



**STIKDD** Outdoor lighting range, downward facing



Stylish design screwless at sight

Extremely silent mechanics

High technological materials resistant to weather conditions

The release system is ergonomic, efficient and easily accessible

## CONTROL UNIT CT10324

### + CT10324



New 5-character / 16-segment display for more natural and intuitive reading

### + KUBEPRO

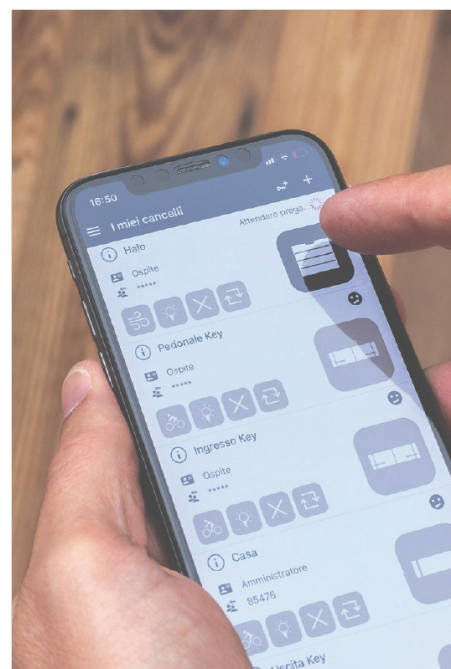
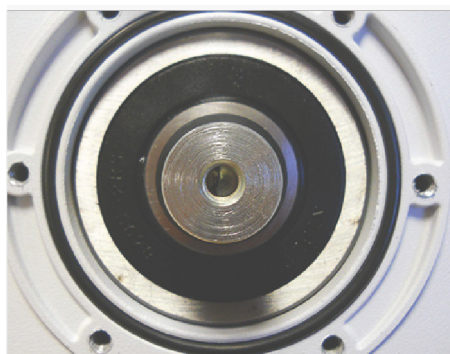
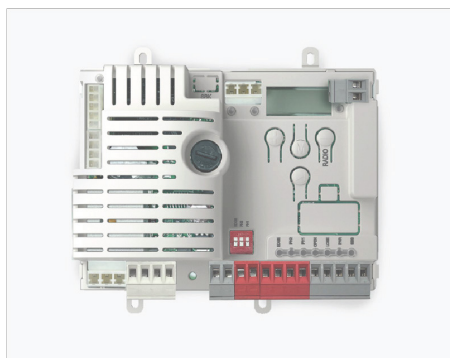
Optional programming with KUBE PRO wireless module (from Firmware version 2.0 and new smartphone app to be released in July 2024).



## MODELS

CODE	DESCRIPTION
  <b>SUN5324M</b>	For sliding gates up to 500 kg, 24 Vdc motor, control unit CT10324 with slowdown and magnetic limit switch. Integrated receiver. Residential use



## TECHNICAL DATA

### SUN5324M

#### MECHANICAL DATA

speed	cm/s	26*
torque	Nm	18
cycles/hour**		40

#### ELECTRICAL DATA

control board		CT10324
automation power supply	Vac	230
frequency	Hz	50/60
motor power supply	Vdc	24
consumption	A	1,2
absorbed power	W	250

#### GENERIC DATA

protection degree	IP	44
dimensions (L - D - H)	mm	
weight	kg	10,7
working temperature	°C	-20 + 55
gate maximum weight	kg	500

## DIMENSIONS

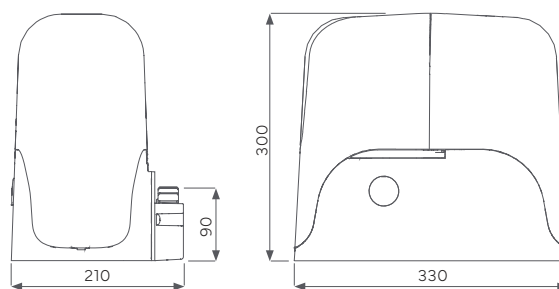

\*The value varies based on the weight of the gate. For co-ownership use, we recommend using 700 kg models.

\*\* The cycles now indicated are with a standard leaf of 2 m length and weight of 200 kg at an ambient temperature of 20°C.

## ACCESSORIES



**RN800** \*M4 nylon rack  
L=1000 mm for gates up to  
800 kg €/m



**CREM-8** \*\*M4 zinc coated rack  
30x8 mm L=1000 mm



**CREM-12** \*\*M4 zinc coated rack  
30x12 mm L=1000 mm



**TWIN** Interface for  
master/slave function  
(SUN7224)



**KCS** Unlock kit with  
key



**SUB remotes** Water and dust  
resistant 433MHz  
transmitters, rolling code



**999ACCE018B00** Magnetic  
Limit switch and bolts accessory  
pack



**KUBE PRO** Wireless  
module for  
programming



**KUBE** Wireless controlling module  
for end user



**RX4K** 4-channel plug-in receiver,  
433MHz, for CT202 control unit



**KPLAY4R** Kit with 2x 4-channel  
433 MHz transmitters, rolling  
code



**FT43** Pair of photocells  
for external use  
adjustable through 180



**FT43B** Pair of photocells for  
external use adjustable through  
180, battery version



**FT33** Pair of photocells for  
external use, flush mounting



**RP25K** Reflective photocells



**ECLIPSE** Led flashing with  
courtesy light, crepuscular  
sensor and built-in antenna



**SEL-R** Wireless keypad  
transmitter, 433MHz



**EGKTR1** Wireless keypad  
transmitter, EGO series 433MHz



**TO1M** 1-channel touch  
transmitter, rolling code 433Mhz



**RXM23Y** 2-channel universal  
receiver, fix or rolling code



**KBP** Kit of 1.3 Ah lead battery  
and battery charger



**KSOLAU** Solar kit,  
includes 30W panel,  
recharge unit in  
enclosure, mounting  
brackets and batteries



**SPLIT24V** Low Voltage box



**EG50** 50cm post for  
accessories

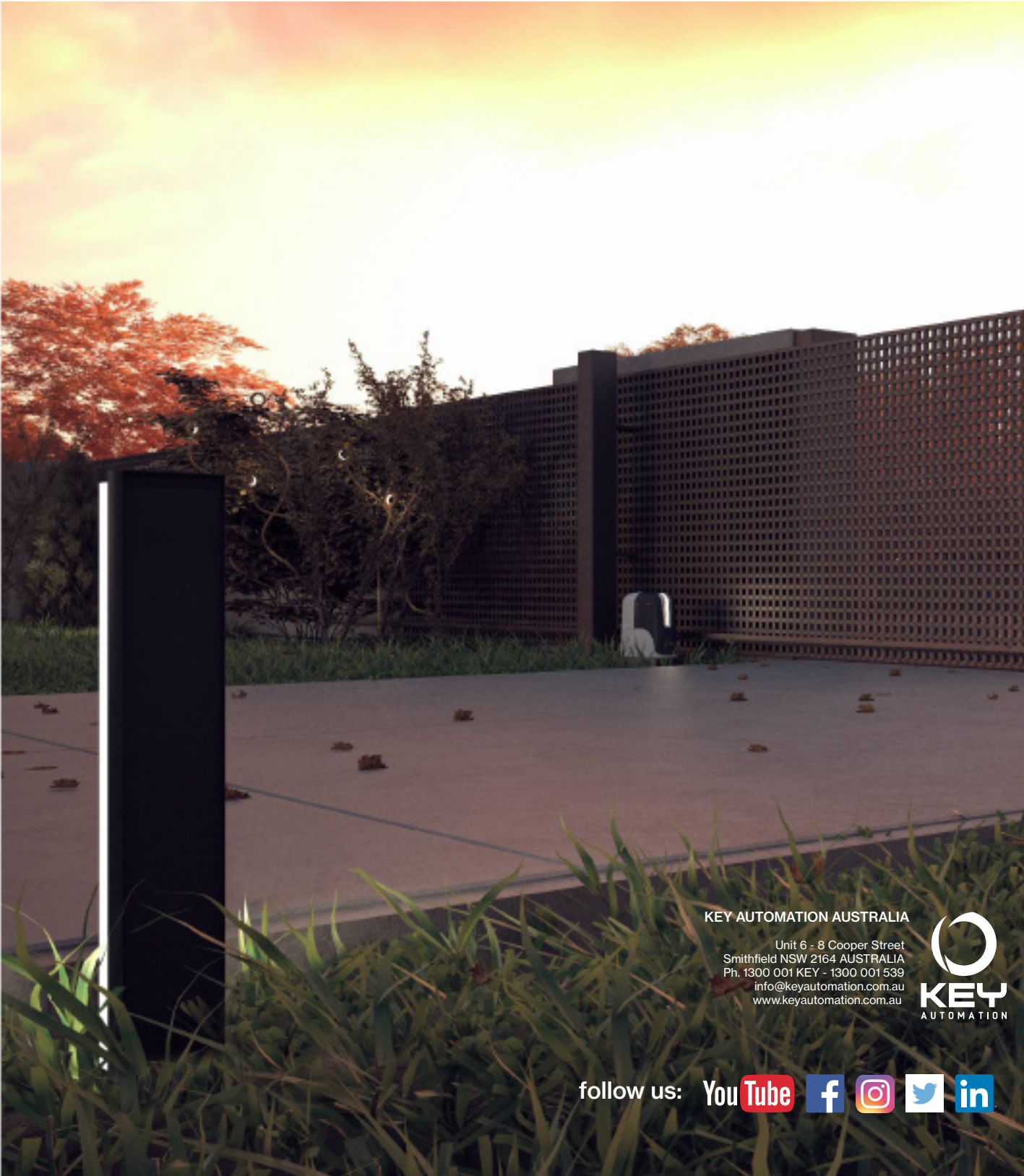

KEY AUTOMATION AUSTRALIA

Unit 6 - 8 Cooper Street  
Smithfield NSW 2164 AUSTRALIA  
Ph. 1300 001 KEY - 1300 001 539  
info@keyautomation.com.au  
www.keyautomation.com.au



follow us:     