

Istruzioni ed avvertenze destinate all'utilizzatore finale
Instructions and warnings for the end user
Instructions et avertissements destinés à l'utilisation final
Instrucciones y advertencias destinadas al usuario final
Anweisungen und hinweise für den endbenutzer
Instruções e advertências destinadas ao utilizador final
Instrukcje i ostrzeżenia kierowane do użytkownika końcowego

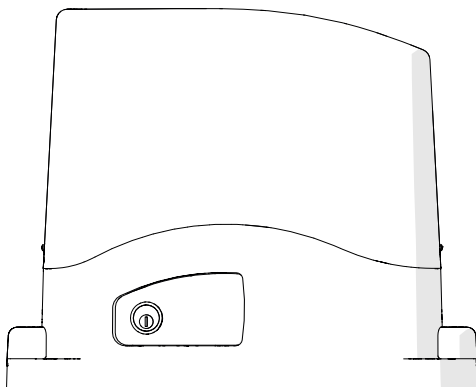

TURBO

Motoriduttori per scorrevoli
Gear-motor for sliding gates
Motoreducteur pour coulissants
Motorreductores para rejas correderas
Getriebe für Schiebegitter
Motorreductores para portões de correr
Napęd silnikowy do bram przesuwnych



Management
System
ISO 9001:2008

www.tuv.com
ID 9105043769

INSTRUCTIONS AND WARNINGS FOR THE END USER

Key Automation S.r.l. produces systems for the automation of gates, garage doors, automatic doors, shutters, parking lots and road barriers. However, Key Automation is not the manufacturer of your automation system, which is rather the result of a process of analysis, evaluation, selection of materials, and installation performed by your own installer. Each automated system is unique and only your installer has the experience and professionalism required to create a system to suit your needs, safe and reliable over time, and carried out in a workmanlike manner, i.e. compliant with the current regulations. Even if your automation system meets the security level required by law, this does not exclude the existence of "residual risks", i.e. the possibility that it may cause dangerous situations, usually as a result of improper or irresponsible use; for this reason we would like to give you some suggestions:

- Before using the automation for the first time, ask the installer to explain the origin of residual risks (Fig.1).
- Keep this manual for future use and deliver it to any new owner of the automation.
- Inappropriate or improper use of the automation can make it dangerous: do not command the movement of the automation if people, animals or things are in its range.
- Children: If properly designed, an automation system ensures a high degree of security, preventing movement in the presence of people or things with its detection systems, and ensuring always predictable and safe activation. It is prudent to prevent children from playing near the automation and keep remote controls out of their reach to prevent accidental activation.
- Malfunctions: As soon as you notice any malfunctions, disconnect the system from the power supply and operate the manual release. Do not attempt any repairs by

yourself, but require the assistance of your installer: meanwhile, the system can operate like a non-automated opening device after releasing the motor reducer with the release key supplied with the system.

- In case of failures or power failures: While awaiting the arrival of your installer or the restore of the electricity, if the system is not equipped with backup batteries, the automation can be operated as any normal non-automated opening device. To do this, you must run the manual release (Fig.2).

Release and manual movement: before performing this operation pay attention that the device can be released only when the door is stationary (Fig.2).

- Maintenance: Like any machine, your automation needs periodic maintenance to ensure its long life and total safety. Agree with your installer on a maintenance plan on a periodic basis; Key Automation recommends a frequency of 6 months for normal domestic use, but this period may vary depending on the intensity of use. All inspection, maintenance or repairs should be performed only by qualified personnel.

ATTENTION !

Cleaning and user maintenance shall not be made by children without supervision.

- Do not change the system and control or programming parameters of the automation: the responsibility lies with your installer.
- The testing, routine maintenance and any repairs must be documented by the person who performs them, and related documents must kept by the owner.

The only interventions that are possible for the user and should be carried out periodically are the cleaning of the slides and photocells, as well as the removal of any leaves

or rocks that could hinder the automation. To prevent anyone from activating the gate or door, before proceeding, remember to release the automation and clean only with a cloth slightly dampened with water.

- Disposal: At the end of the automation useful life, make sure that the dismantling is carried out by qualified personnel and the materials are recycled or disposed of according to local regulations in force.
- Operate the gate or door (with remote control, key switch, etc.); if everything is working properly, the gate or the door will open and close normally, otherwise the flashing light flashes and the maneuver does not start.

With the safeties out of use, the automation must be repaired as soon as possible.

Replacing the remote control battery: if your remote control seems to work worse or not work at all after a while, this may simply depend on the exhaustion of the battery (depending on use, it may take several months to over a year). In that case, you will see that the confirmation of transmission light does not turn on, or comes on only briefly.



The batteries contain polluting substances: do not throw them in the garbage but use the methods prescribed by local regulations.

Thank you for choosing key Automation; for more information feel free to visit our website www.keyautomation.com.



ATTENTION !

A more recent version of the manual supplied may be available for download at www.keyautomation.com; check for updates.

IMAGES

Fig. 1 IT - ATTENZIONE !
EN - ATTENTION !
FR - ATTENTION !
ES - ATENCIÓN !

DE - ACHTUNG !
PT - ATENÇÃO !
PL - UWAGA !

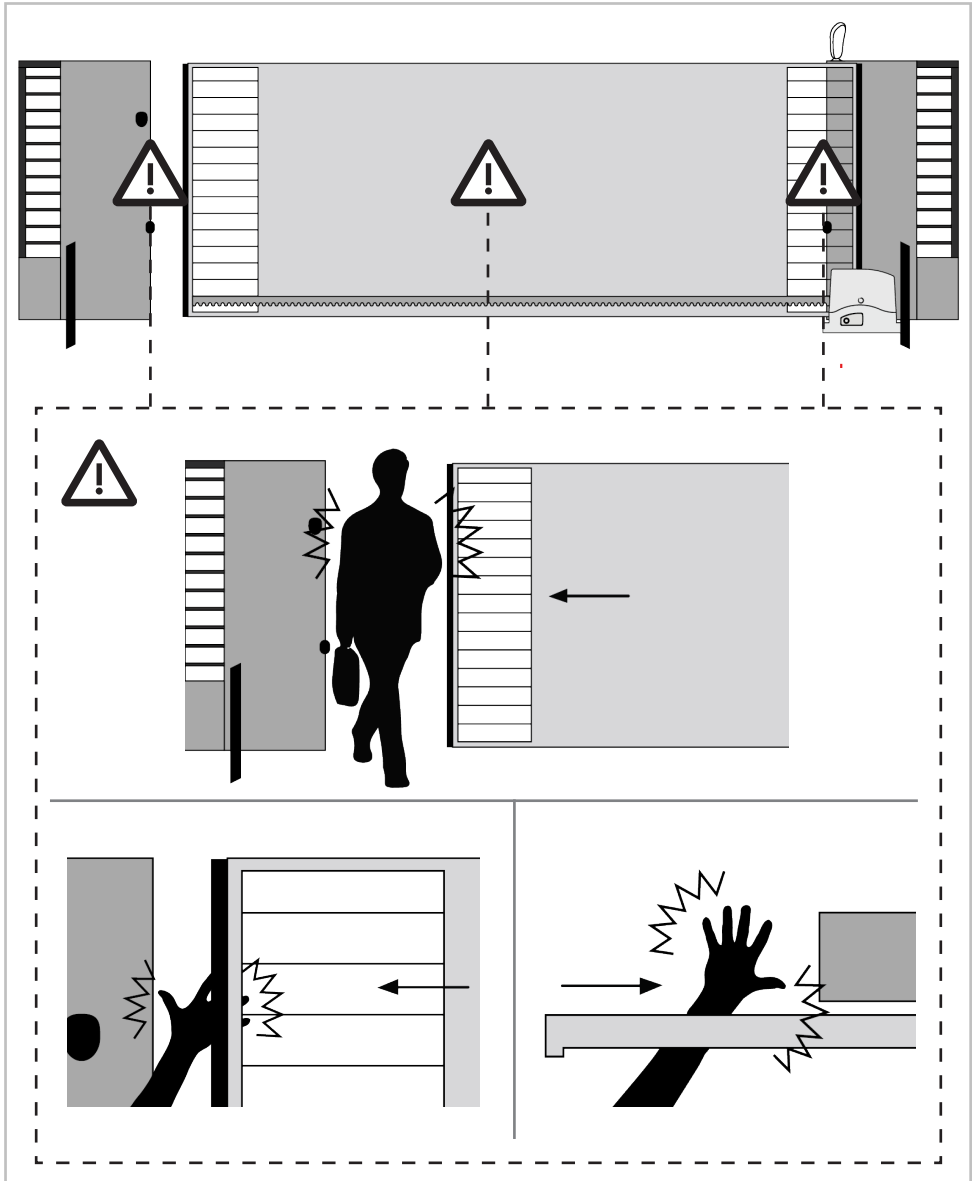

Fig. 2 IT - Sblocco di emergenza
EN - Emergency unblocking
FR - Déverrouillage d'urgence
ES - Desbloqueo de emergencia

DE - Notfallfreigabe
PT - Desbloqueio de emergência
PL - Odblokowanie awaryjne

IT Inserire la chiave e ruotarla in senso antiorario di 90°.

EN Insert the key and turn it 90° in anticlockwise direction.

FR Insérer la clé et la tourner dans le sens inverse des aiguilles d'une montre de 90°.

ES Introducir la llave y girarla en sentido antihorario de 90°.

DE Den Schlüssel einstecken und um 90° drehen.

PT Introduza a chave e rode-a 90° para a direita.

PL Włóż klucz i obróć go o 90° w kierunku przeciwnym do ruchu wskazówek zegara.

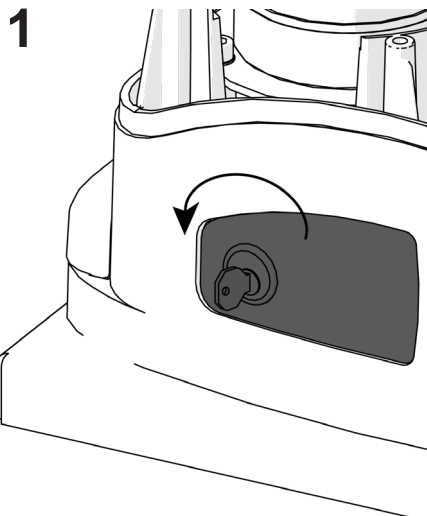

IT Tirare la maniglia fino a portarla perpendicolare al motoriduttore.

EN Pull the knob till it is perpendicular to the gearmotor.

FR Tirer vers soi la poignée et la disposer perpendiculairement au motoréducteur.

ES Jalar hacia sí el tirador hasta llevarlo perpendicular al motorreductor.

DE Den Griff so weit zum Körper hinziehen, dass er senkrecht zum Antrieb steht.

PT Puxe a pega para si até ela ficar perpendicular ao motorreductor.

PL Pociągnij za gałkę, aż znajdzie się w pozycji prostopadłej do napędu silnikowego.

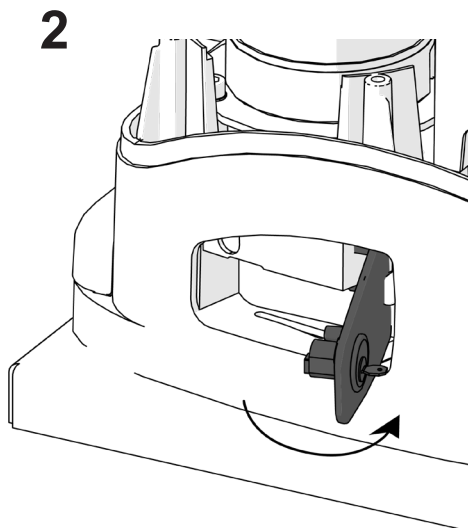

INSTALLER DATA

INSTALLER DATA

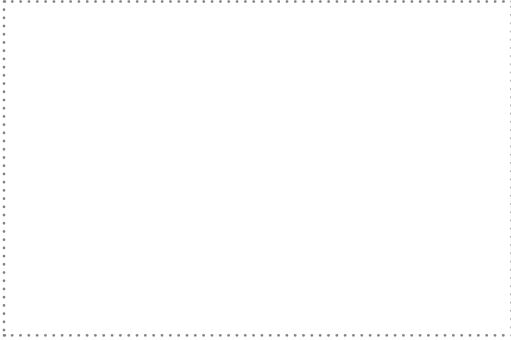

DATE



SIGNATURE



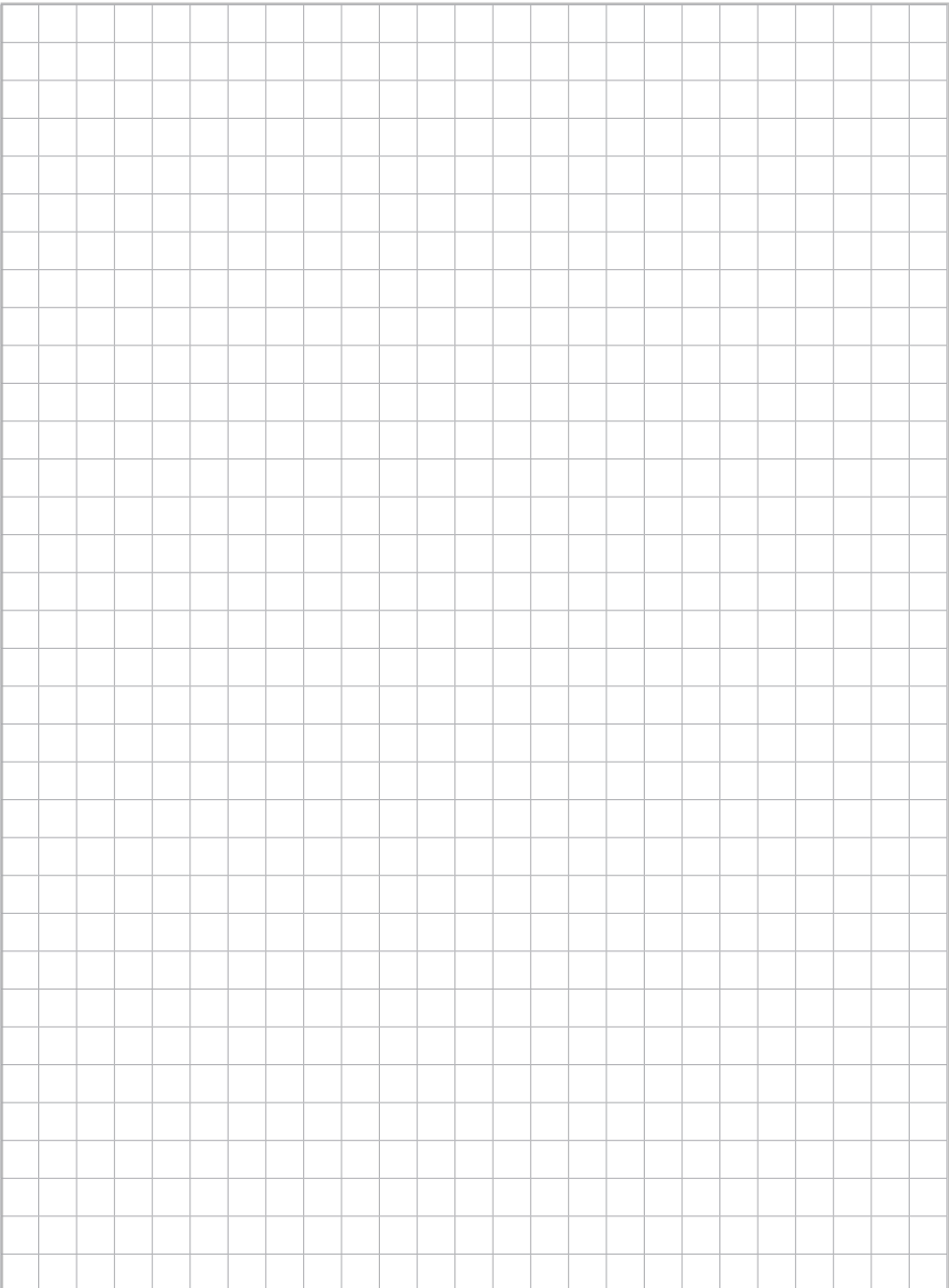

Key Automation S.r.l.

Via Meucci 23 - 30027 San Donà di Piave (VE)

T. +39 0421 307456

info@keyautomation.it | www.keyautomation.com

Instruction version

580TU REV01