

# CT10324

**Control unit for a 24 Vdc motor, for a sliding gate or up-and-over door**  
**Centrale per un motore 24 Vdc, per cancello scorrevole o portone basculante**  
**Logique de commande pour un moteur 24 Vdc, pour portail coulissant ou porte basculante**  
**Central para un motor 24 Vdc, para puerta de corredera o portón basculante**  
**Steuergerät für einen Motor 24 Vdc, für Schiebetor oder Schwingtor**  
**Unidade para um motor 24 Vdc, para portão de correr ou portão basculante**  
**Jednostka sterująca do silnika 24 Vdc obsługującego bramę przesuwную lub wahadłowe drzwi**



# INDEX

<b>1 - Safety warnings</b>	<b>4</b>
<b>2 - Introducing the product</b>	<b>5</b>
2.1 - Description of the control unit	5
2.2 - Description of the connections	5
2.3 - Models and technical characteristics	5
2.4 - List of cables required	6
<b>3 - Preliminary checks</b>	<b>6</b>
<b>4 - Product installation</b>	<b>7</b>
4.1 - Electrical connections	7
4.2 - Disabling the safety devices	9
4.3 - Display during normal operation	9
4.3.1 - <i>Error messages on the display</i>	10
4.3.2 - <i>Error messages on flashing light</i>	10
4.3.3 - <i>Status messages on display</i>	10
4.4 - Autolearning of the travel stroke	10
4.4.1 - <i>Autolearning of the travel stroke and main parameters</i>	11
4.4.2 - <i>Autolearning of the travel stroke and main parameters, with customised decelerations</i>	11
4.5 - Radio remote control management	12
4.5.1 - <i>Memorisation of buttons of a radio remote control</i>	12
4.5.2 - <i>Deletion of a memorised button of a radio remote control</i>	12
4.5.3 - <i>Deletion of the entire receiver memory</i>	13
4.5.4 - <i>Memorisation of a button of a new radio remote control using a radio remote control already saved in memory</i>	13
4.6 - Factory parameters reset	13
<b>5 - System customisation</b>	<b>14</b>
5.1 - Basic parameters	14
5.2 - Advanced parameters	15
<b>6 - Testing and commissioning the automation system</b>	<b>17</b>
6.1 - Testing	17
6.2 - Commissioning	17
<b>7 - Instructions and warnings for the end user</b>	<b>18</b>

## 1 - SAFETY WARNINGS

### WARNING !

**ORIGINAL INSTRUCTIONS - important safety instructions. Compliance with the safety instructions below is important for personal safety. Save these instructions.**

Read the instructions carefully before proceeding with installation.

**The design and manufacture of the devices making up the product and the information in this manual are compliant with current safety standards. However, incorrect installation or programming may cause serious injury to those working on or using the system. Compliance with the instructions provided here when installing the product is therefore extremely important.**

If in any doubt regarding installation, do not proceed and contact the Key Automation Technical Service for clarifications.

**Under European legislation, an automatic door or gate system must comply with the standards envisaged in the Directive 2006/42/EC (Machinery Directive) and in particular standards EN 12453; EN 12635 and EN 13241-1, which enable declaration of presumed conformity of the automation system.**

Therefore, final connection of the automation system to the electrical mains, system testing, commissioning and routine maintenance must be performed by skilled, qualified personnel, in observance of the instructions in the "Testing and commissioning the automation system" section.

The aforesaid personnel are also responsible for the tests required to verify the solutions adopted according to the risks present, and for ensuring observance of all legal provisions, standards and regulations, with particular reference to all requirements of the EN 12453 standard which establishes the test methods for testing door and gate automation systems.

### WARNING !

**Before starting installation, perform the following checks and assessments:**

ensure that every device used to set up the automation system is suited to the intended system overall. For this purpose, pay special attention to the data provided in the "Technical specifications" section. Do not proceed with installation if any one of these devices is not suitable for its intended purpose;

check that the devices purchased are sufficient to guarantee system safety and functionality;

perform a risk assessment, including a list of the essential safety requirements as envisaged in Annex I of the Machinery Directive, specifying the solutions adopted. The risk assessment is one of the documents included in the automation system's technical file. This must be compiled by a professional installer.

**Considering the risk situations that may arise during installation phases and use of the product, the automation system must be installed in compliance with the following safety precautions:**

never make modifications to any part of the automation system other than those specified in this manual. Operations of this type can only lead to malfunctions. The manufacturer declines all liability for damage caused by unauthorised modifications to products;

if the power cable is damaged, it must be replaced by the manufacturer or its after-sales service, or in all cases by a person with similar qualifications, to prevent all risks;

do not allow parts of the automation system to be immersed in water or other liquids. During installation ensure that no liquids are able to enter the various devices;

should this occur, disconnect the power supply immediately and contact a Key Automation Technical Service. Use of the automation

system in these conditions may cause hazards;

never place automation system components near to sources of heat or expose them to naked lights. This may damage system components and cause malfunctions, fire or hazards;

all operations requiring opening of the protective housings of various automation system components must be performed with the control unit disconnected from the power supply. If the disconnect device is not in a visible location, affix a notice stating: "MAINTENANCE IN PROGRESS":

connect all devices to an electric power line equipped with an earthing system;

the product cannot be considered to provide effective protection against intrusion. If effective protection is required, the automation system must be combined with other devices;

the product may not be used until the automation system "commissioning" procedure has been performed as specified in the "Automation system testing and commissioning" section;

the system power supply line must include a circuit breaker device with a contact gap allowing complete disconnection in the conditions specified by class III overvoltage;

use unions with IP55 or higher protection when connecting hoses, pipes or cable glands;

the electrical system upstream of the automation system must comply with the relevant regulations and be constructed to good workmanship standards;

users are advised to install an emergency stop button close to the automation system (connected to the control PCB STOP input) to allow the door to be stopped immediately in case of danger;

this device is not intended for use by persons (including children) with impaired physical, sensory or mental capacities, or with lack of experience or skill, unless a person responsible for their safety provides surveillance or instruction in use of the device;

before starting the automation system, ensure that there is no-one in the immediate vicinity;

before proceeding with any cleaning or maintenance work on the automation system, disconnect it from the electrical mains;

special care must be taken to avoid crushing between the part operated by the automation system and any fixed parts around it;

children must be supervised to ensure that they do not play with the equipment.

### WARNING !

**Packaging components (cardboard, plastic, etc.), duly separated, must be placed in the appropriate bins. Device components such as electronic boards, metal parts, batteries, etc. must be separated and differentiated. For the methods of disposal, the rules in force in the place of installation must be applied. DO NOT DISPOSE IN THE ENVIRONMENT!**



**KEY AUTOMATION S.r.l. reserves the right to amend these instructions if necessary; they and/or any more recent versions are available at [www.keyautomation.com](http://www.keyautomation.com)**

## 2 - INTRODUCING THE PRODUCT

### 2.1 - Description of the control unit

The CT10324 control unit is the most modern and efficient control device for 24VDC Key Automation gear motors for sliding gates; any other use is to be considered improper and is therefore prohibited. The 5-digit/14-segment display of the CT10324 control unit makes

it easier to read the acronyms, facilitating programming and monitoring of the automation; the menu structure allows easy setting of work times and operating modes.

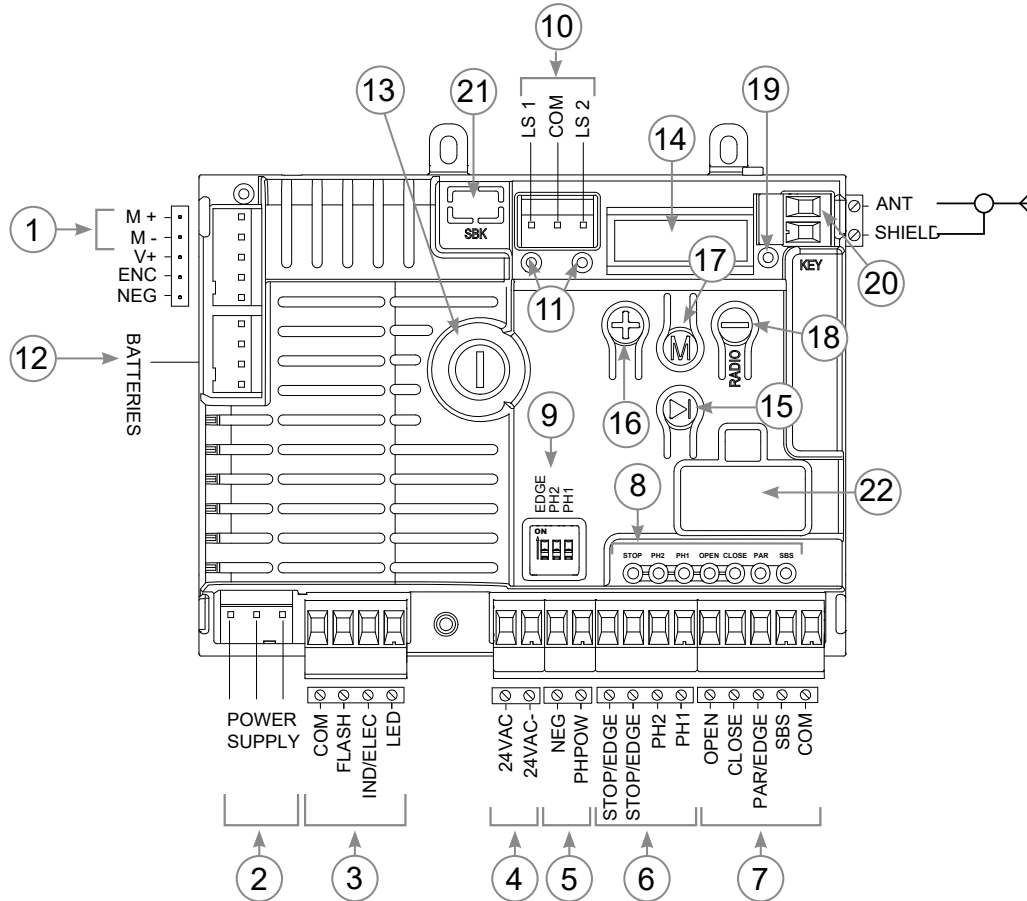

### 2.2 - Description of the connections

- |  |   |
|--|---|
| <ul style="list-style-type: none"> <li>1- Motor power supply (M+ and M-)</li> <li>2- Transformer power connector</li> <li>3- Connection of flashing light, gate open/electric lock warning light, courtesy light</li> <li>4- 24 VAC connector for control and safety devices</li> <li>5- 24 VDC unregulated for safety devices (photocell and radio safety edge)</li> <li>6- Safety input for STOP connection or edge and photocell</li> <li>7- Connector for control devices</li> <li>8- Red safety LED for EDGE, PH2, PH1 inputs; Green LED for OPEN, CLOSE, PAR, SBS inputs</li> <li>9- DIP SWITCH safety exclusion toggle switch</li> <li>10- Connector for limit switches</li> <li>11- Red LED indicators for limit switches</li> </ul> | <ul style="list-style-type: none"> <li>12- Connector for KBP/KBPN battery charger</li> <li>13- 1.6 AT fuse (timed)</li> <li>14- 5-digit, 14-segment function display</li> <li>15- Movement button (SBS)</li> <li>16- Button (UP)</li> <li>17- Button (MENU)</li> <li>18- Button (DOWN-RADIO)</li> <li>19- LED RADIO indicator</li> <li>20- Antenna</li> <li>21- SBK: fitting for energy saving module when the control unit is not active (optional)</li> <li>22- Connector for KUBE / PowerBus interface (optional)</li> </ul> |
|--|---|

### 2.3 - Models and technical characteristics

CODE	DESCRIPTION
CT10324	24V control unit for a sliding gate, overhead door or barrier

- Electronic protection against short circuit and overload at the FLASH, IND/ELEC and LED outputs
- Protection of 24VAC and PH-POW outputs via resettable fuses
- Automatic obstacle detection
- Auto-learning of the stroke length
- Disabling of unused safety inputs via dip switch: it is not necessary to insert jumpers on the respective input terminals (paragraph 4.2)

TECHNICAL SPECIFICATIONS	CT10324
Power Supply	24 VAC (+10% -15%) 50/60 Hz
Maximum motor power	200 W
Maximum output current 24VAC	200 mA (24 VAC)
PH-POW maximum output current	200 mA (24 VDC non-regulated)
Maximum FLASH output power	15 W (24 VDC)
Maximum LED output power	15 W (24 VDC)
Maximum power for the "IND/ELEC" output	5 W (24 VDC) / 15 VA (12 VDC)
Control unit fuse	1.6 AT (timed)
Integrated radio receiver	433.92 MHz OOK
Antenna	wire or cable antenna RG58
Number of saved transmitters	150

## 2.4 - List of cables required

The following table shows the cables necessary for connection of the various devices in a typical system.  
The cables must be suitable for the type of installation; for example,

we recommend a cable type H03VV-F for installation indoors or H05RN-F/H07RN-F if installed outdoors.

ELECTRIC CABLE TECHNICAL SPECIFICATIONS		
CONNECTION	CABLE	MAXIMUM PERMITTED LIMIT
Power supply line	3 x 1,5 mm <sup>2</sup>	< 20 m
	3 x 2,5 mm <sup>2</sup>	> 20 m (50 m max) Connect the earth wire near the control unit
Flashing light (FLASH) Courtesy light (LED)	3 x 0,55 mm <sup>2</sup>	20 m
Antenna	cable RG58	10 m (recommended < 5 m)
Electric locking (IND/ELEC)	2 x 1,5 mm <sup>2</sup>	10 m
Photocells (transmitter)	2 x 0,55 mm <sup>2</sup>	20 m
Photocells (receiver)	4 x 0,55 mm <sup>2</sup>	20 m
Safety edge	2 x 0,55 mm <sup>2</sup>	20 m
Key switch	4 x 0,55 mm <sup>2</sup>	20 m
Motors power supply	2 x 1,5 mm <sup>2</sup>	10 m

## 3 - PRELIMINARY CHECKS

Before installing the product, perform the following checks and inspections:

check that the gate, the door or the barrier is suitable for automation; the weight and size of the gate or door and the balance of the barrier boom must be within the operating limits specified for the automation system in which the product is installed;  
check that the gate or door has firm, effective mechanical safety stops;

make sure that the product fixing zone is not subject to flooding; high acidity or salinity or nearby heat sources might cause the product to malfunction;

in case of extreme weather conditions (e.g. snow, ice, wide temperature variations or high temperatures), friction may increase, causing a corresponding rise in the force needed to operate the system; the starting torque may therefore exceed that required in normal

conditions;

check that when operated by hand the gate, the door or the barrier moves smoothly without any areas of greater friction or derailment risk;

check that the gate, door or the barrier is well balanced and will therefore remain stationary when released in any position;

check that the electricity supply line to which the product is to be connected is suitably earthed and protected by an overload and differential safety breaker device;

the system power supply line must include a circuit breaker device with a contact gap allowing complete disconnection in the conditions specified by class III overvoltage;

ensure that all the material used for installation complies with the relevant regulatory standards.

# 4 - PRODUCT INSTALLATION

## 4.1 - Electrical connections

**⚠ WARNING !** Before making the connections, ensure that the control unit is not powered up.

### MOTOR CONNECTION

#### Power supply connection terminal board

M1 +	Power supply of motor M1 +
M1 -	Power supply of motor M1 -
V +	DO NOT USE
ENC	DO NOT USE
NEG	DO NOT USE

### POWER SUPPLY CONNECTOR

L	Power supply live 230 Vac (120 Vac) 50-60 Hz
N	Power supply neutral 230 Vac (120 Vac) 50-60 Hz
⊕	Earth

### DIP SWITCH

Set on "ON" to disable inputs EDGE, PH1, PH2  
This procedure avoids to bridge the terminal board inputs.

**⚠ WARNING !** with the dip switch ON, the safety devices are disabled.

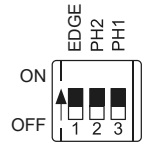

**EXAMPLE:** With only 1 photocell connected set EDGE and PH2 to ON



To disable, follow the procedure at paragraph 4.2

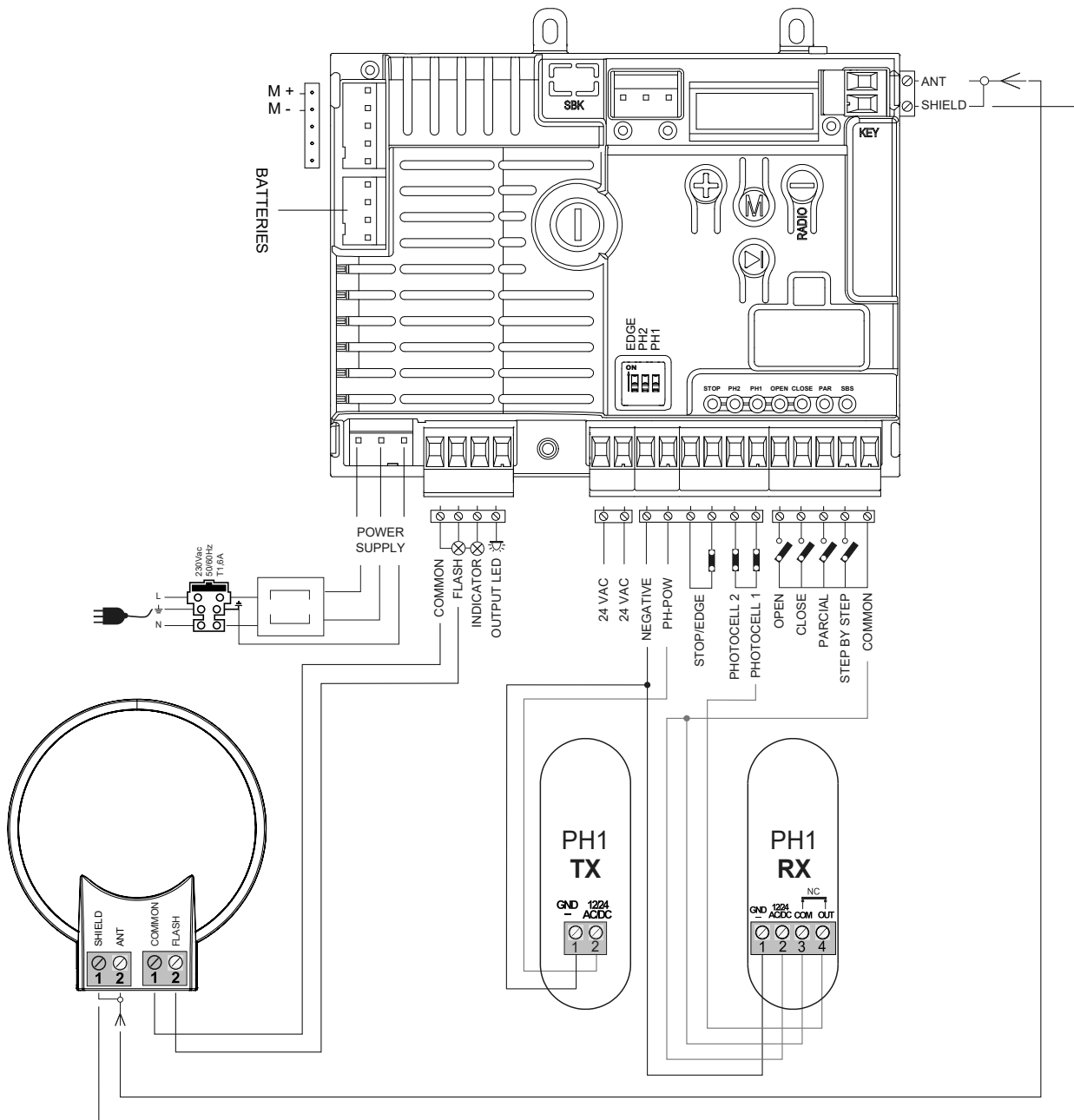

**ELECTRICAL CONNECTIONS FOR ENERGY SAVING**

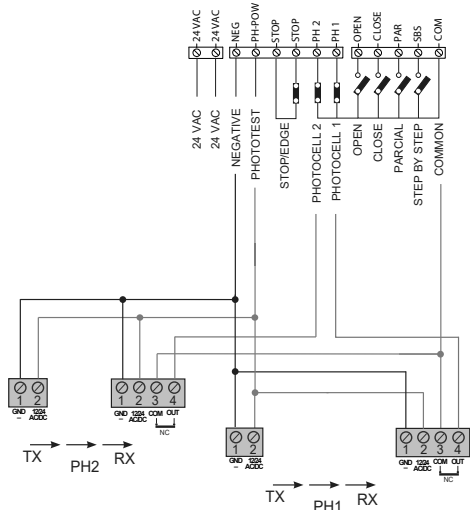

**⚠ WARNING !** To enable **STANDBY** see paragraph 5.1, point 12. Only during this function **PHOTEST** is not possible

**ELECTRICAL CONNECTIONS FOR PHOTO1 AND PHOTO2**

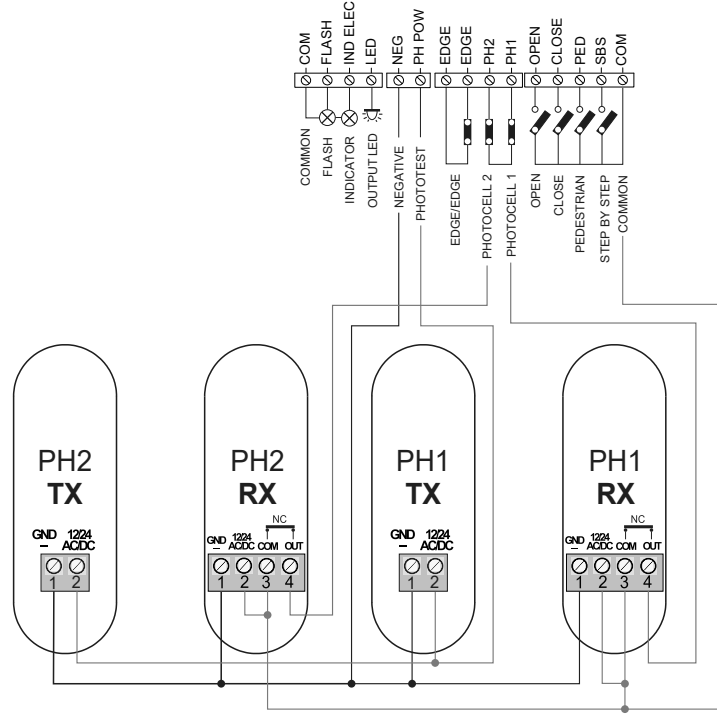

**SAFETY AND CONTROL DEVICE CONNECTORS**

24 VAC	Accessory power supply 24VAC non-regulated 200mA MAX; <b>not active during battery operation</b>
24 VAC	
COM	Common positive for FLASH - IND/ELEC - LED and accessories outputs
IND/ELEC	IND, gate open warning light output, 24VDC 5W MAX ELEC, electric lock output 12VDC 15VA MAX selectable with the <b>INDIC LIGHT</b> parameter (paragraph 5.2, point 17)
LED	Courtesy light output, 24VDC non-regulated 15W MAX also controllable via radio remote control
NEG	Negative power supply for accessories
PH-POW	Positive power supply for PH1 and PH2 photocells; operating mode configurable with the <b>PHOTO TEST</b> parameter (paragraph 5.2, point 3)
EDGE	8k2/NC safety edge contact input; operating mode configurable with the <b>EDGE</b> parameter (paragraph 5.2, point 4)
EDGE	<b>⚠ WARNING !</b> with the <b>EDGE</b> dip switch in the ON position the input is always disabled
PH2	PH2 opening photocell NC input; at any time during opening/closing, the intervention of the photocell (opening of the contact) causes the movement to immediately stop. Closing the contact restores the opening operation. The operating modes can be configured with the <b>PHOTO 2 SETUP</b> parameter (paragraph 5.2, point 2) <b>⚠ WARNING !</b> with the PH2 dip switch in the ON position the input is always disabled
PH1	PH1 closing photocell NC input; at any time during closing, the intervention of the photocell (opening of the contact) causes blocking and reversal of the direction of travel. While PH1 is active it is not possible to close the gate. The operating modes can be configured via the <b>PHOTO 1 SETUP</b> parameter (paragraph 5.2, point 1) <b>⚠ WARNING !</b> with the PH1 dip switch in the ON position the input is always disabled
OPEN	NO OPENING command input; MAN PRESENT function configurable with the <b>HOLD TO RUN</b> parameter (paragraph 5.2, point 16)
CLOSE	NO CLOSING command input; MAN PRESENT function configurable with the <b>HOLD TO RUN</b> parameter
PAR	NO PARTIAL OPENING command input, also configurable as a second safety edge/STOP via <b>STOP TWO</b> parameter; With the <b>STOP TWO</b> parameter the input can be configured as a second safety edge (paragraph 5.1, point 9) MAN PRESENT function configurable with the <b>HOLD TO RUN</b> parameter
SBS	NO STEP-BY-STEP command input (SBS); upon each activation the commands AP (open) - ST (stop) - CH (close) are executed in succession; the operating modes are configurable with the <b>SBS SETUP</b> parameter. MAN PRESENT function configurable with the <b>HOLD TO RUN</b> parameter
COM	Common positive inputs PH2, PH1, OPEN, CLOSE, PAR, SBS
SHIELD	Antenna - shield
ANT	Antenna - signal



## 4.2 - Disabling the safety devices

### EDGE

The control unit provides (default setting) for the installation of a safety edge connected to the EDGE inputs; in the event of a missing or incorrect connection, the operation of the automation is inhibited. In a system where a safety edge is not to be installed, its use can be disabled by setting the EDGE dip-switch to ON.

**⚠ WARNING !** confirm the safety edge deactivation by pressing and holding the buttons ⊕ and ⊖ until the EDGE LED stops flashing.

### PHOTO 2

The control unit provides (default setting) for the installation of one or more photocells connected to the PH2 input, in the event of a missing or incorrect connection, the operation of the automation is inhibited. In a system where a PH2 is not to be installed, its use can be disabled by setting the PH2 dip-switch to ON.

**⚠ WARNING !** confirm the PH2 deactivation by pressing and holding the buttons ⊕ and ⊖ until the PH2 LED stops flashing.

### PHOTO 1

The control unit provides (default setting) for the installation of one or more photocells connected to the PH1 input, in the event of a missing or incorrect connection, the operation of the automation is inhibited. In a system where a PH1 is not to be installed, its use can be disabled by setting the PH1 dip-switch to ON.

**⚠ WARNING !** confirm PH1 input deactivation by pressing the ⊕ and ⊖ buttons simultaneously and holding them down until the PH1 LED stops flashing.

## 4.3 - Display during normal operation

The following table shows the messages displayed during normal operation of the automation.

MESSAGES	MEANING
LEARN TODD	The door travel has not been learned; perform the auto-learning procedure
READY	Gate closed, control panel restarted
OPENING	The gate is opening
CLOSING	The gate is closing
STOP OPEN	The gate was stopped during the opening manoeuvre
STOP CLOSE	The gate was stopped during the closing manoeuvre
FOTO1	PH1 intervention (photocell 1)
FOTO2	PH2 intervention (photocell 2)
ALIGNMENT	The automation is performing the realignment procedure
OPEN	Gate open, automatic closing timer not active
PARTIAL	The gate is performing a partial opening
PART OPEN	The gate is stopped in the partially open position
TIME CLOSE	The gate has reached the open position and automatic re-closing is active; the display alternately shows TIME CLOSE. During the last ten seconds, the seconds remaining until re-closing
TIME PART	The gate has been opened with the PAR command and the automatic re-closing timer from partial opening is active; during the last ten seconds, the seconds remaining until re-closing are indicated
LEARN STOP	Auto-learning procedure blocked due to safety intervention or intentional stop
LEARN OPEN1	Auto-learning of leaf 1 opening travel
LEARN CLOS1	Auto-learning of leaf 1 closing travel
SLOW OPEN1	Personalised learning of the slowdown point during leaf 1 opening
SLOW CLOS1	Personalised learning of the slowdown point during leaf 1 closing

#### 4.3.1 - Error messages on the display

To cancel the error message on the display, after having eliminated the cause of the anomaly, perform a complete opening or closing manoeuvre, i.e. until the relevant limit switch is reached. Alternatively, briefly press the **M** MENU button (the automation does not perform any movement).

<b>MOTOR OVERLOAD</b>	The current of a motor has increased very rapidly
OVERLOAD	1. The gate has struck an obstacle
<b>SAFETY EDGE</b>	The control unit has detected the activation of the safety edge
EDGE	1. The safety edge is active 2. The safety edge is not connected correctly
<b>PHOTOCELL TEST</b>	The photocell or safety edge test has failed
FOTO TEST	1. Check the correct functioning of the photocells 2. Check the photocell connections

#### 4.3.2 - Error messages on flashing light

The events reported in the following table are signalled by the flashing light and the KEY LED present in the control unit.

FLASHING INDICATION AND LED KEY ON CONTROL UNIT	EVENT	DESCRIPTION
2 quick flashes + pause + 1 flash	auto-learning	Auto-learning phase in progress
4 quick flashes + pause, for three times	Obstacle detected	A leaf has struck against an obstacle
2 quick flashes + pause, for three times	Photo1 / Photo2	A photocell has been activated
5 quick flashes + pause, for three times	Safety edge	The safety edge has been activated
3 quick flashes + pause, for three times	The photo test has failed	The photocells or sensitive edge test has failed
6 quick flashes + pause, for three times	Short circuit overload	Anomaly in one of the FLASH, ELS/SCA or LED outputs

#### 4.3.3 - Status messages on display

Repeatedly pressing the **+** (UP) button displays additional information described in the following table. To return to the normal status, press the **M** (MENU) button.

DISPLAY	MEANING
READY, OPENING, EDGE, FOTO TEST, ecc.	Automation status
NCY500	Total number of complete opening + closing manoeuvres
IM1E0200	Instantaneous current absorbed by motor M1, in mA
CT10324 FW2.0 SN635A33F	Card type – firmware version – card serial number

#### 4.4 - Autolearning of the travel stroke

Upon the first start-up or in the event of a modification of the equipment model, which involves restoring the factory values, the message **LEARN TO GO** appears on the display and the auto-learning procedure of the operating parameters must be performed (width of the movement angle of the doors, slowdown points in

opening and closing, ...).

**⚠ WARNING !** Select the correct motor before starting the auto-learning procedure (**MOTOR SETUP**, paragraph 5.2 - Advanced parameters).

### 4.4.1 - Autolearning of the travel stroke and main parameters

1. Unlock the gear motor, bring the gate to approximately half its travel and lock the gear motor again.

2. To start the auto-learning procedure, simultaneously press and hold the **+** (UP) and **M** ((MENU) buttons; after approximately two seconds the gate begins to open slowly; the display shows **LEARN OPEN I**.

**⚠ WARNING !** If the leaf moves in the closing direction, stop the movement by pressing the **⊖** (DOWN-RADIO) button; press the **▶** (SBS) button to resume the learning procedure with the direction of movement reversed.

3. Once the opening limit switch is reached the motor stops. After approximately two seconds the gate begins to move towards the closing direction; the display shows **CLOSE I LEARN**

4. The stroke auto-learning operation ends when the closing limit switch is reached.

**⚠ WARNING !** The travel auto-learning operations must be fully and correctly completed before putting the equipment into operation; their interruption is only possible by intervening on the safety devices (EDGE, PH2, PH1) or by cutting off power to the control unit.

5. After having correctly completed the travel auto-learning procedures, perform a few complete opening and closing manoeuvres of the gate to check its correct functioning.

After having successfully completed the auto-learning it will be possible to modify the operating parameters by accessing the **BASE** and/or **ADV** parameters menu (paragraph 5)

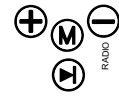

### 4.4.2 - Autolearning of the travel stroke and main parameters, with customised decelerations

The default low speed travel length is 20% of the total travel length. It is possible to change the default value of the travel width performed at low speed, both in opening and closing, by acting on the **LENGTH SLOW** parameter in the **BASE** menu by selecting P (customised). See paragraph 5.1, point 10

1. Unlock the gear motor, bring the gate to approximately half its travel and lock the gear motor again.

2. To start the learning procedure, simultaneously press and hold the **+** (UP) and **M** (MENU) buttons for approximately two seconds; after around two seconds the gate slowly begins to move towards the opening direction; the display shows **LEARN OPEN I**.

**⚠ WARNING !** If the gate moves in the closing direction, stop the movement by pressing the **⊖** (DOWN-RADIO); button; press the **▶** (SBS) button to resume the learning procedure with the direction of movement reversed.

3. Once the opening limit switch is reached the motor stops. After approximately two seconds the gate begins to move towards the closing direction; the display shows **CLOSE I LEARN**

4. Having reached the point where it is necessary to start the slowing down phase (in closing), press the SBS button (**▶**); the display shows **CLOSE I SLOW**

5. Once the closing limit switch has been reached, the motor stops and after approximately two seconds it starts moving again towards the opening direction; the display shows **OPEN I LEARN**

6. Having reached the point where it is necessary to start the slowing down phase (in opening), press the SBS button (**▶**); the display shows **OPEN I SLOW**

7. Once the opening limit switch has been reached, the motor stops; subsequently the closing manoeuvre is performed. When the gate is closed again, the auto-learning procedure of the travel with customised slowdown points is finished.

**⚠ WARNING !** If during the various opening/closing manoeuvres one of the deceleration points is not set, it will automatically be set to 20% of the total travel length.

**⚠ WARNING !** The travel auto-learning operations must be fully and correctly completed before putting the equipment into operation; their interruption is only possible by intervening on the safety devices (EDGE, PH2, PH1) or by cutting off power to the control unit.

After having successfully completed the auto-learning it will be possible to modify the operating parameters by accessing the **BASE** and/or **ADV** parameters menu (paragraph 5)

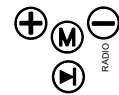

## 4.5 - Radio remote control management





To save the buttons of a radio remote control, delete them or delete all the saved radio remote controls, use the **RADIO** menu. To access the **RADIO** menu, press the **⊖** (DOWN-RADIO) button for approximately two seconds; the wording **RADIO MENU** appears alternatively on the display.

**NOTE:** the control unit exits the **RADIO** menu after seven seconds of inactivity or by briefly pressing the **Ⓜ** (MENU) button.





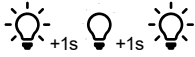

**NOTE:** to facilitate saving operations, thereby minimising any interference, it is advisable to disconnect the receiver's antenna wire; therefore, the procedure only works near the control panel itself.

**⚠ WARNING !** Once the operations have been completed, reconnect the antenna wire to the control panel receiver.



















### 4.5.1 - Memorisation of buttons of a radio remote control

<p>1. Exit any menu, press and hold the button <b>⊖</b> (DOWN-RADIO) until the display shows, alternatively, <b>RADIO MENU</b>.</p>	
<p>2. Press and release the <b>⊖</b> (DOWN-RADIO) button a number of times equal to the function to be activated: once for the STEP BY STEP output (<b>LEARN SBS</b>), twice for the PARTIAL output (<b>LEARN PRR</b>), three times for the ONLY OPEN output (<b>LEARN OPEN</b>), 4 times for the LIGHT ON/OFF output (<b>LEARN LIGHT</b>), 5 times for <b>LEARN ALL</b> (key 1 = SBS, key 2 = PARTIAL, key 3 = ONLY OPEN, key 4 = LIGHT ON/OFF). <b>NOTE:</b> if the courtesy lights are activated by radio remote control, they will only be deactivated by radio remote control.</p>	
<p>3. Immediately after pressing the button <b>⊖</b> (DOWN-RADIO), the KEY LED briefly flashes a number of times corresponding to the selected function interspersed with a pause of approximately one second.</p>	
<p>4. Near the control unit, within seven seconds press the button on the radio remote control to which to associate the selected function; keep the radio remote control button pressed for a few seconds. <b>NOTE:</b> for the pre-set function (5) press any button.</p>	
<p>5. A long flash (approximately three seconds) of the KEY LED confirms correct storage. <b>⚠ WARNING !</b> If the KEY LED emits a series of short flashes, the radio remote control button you are trying to memorise is already present in the memory. <b>NOTE:</b> after having memorise the radio remote control button, within seven seconds, it is possible to associate another button of the same radio remote control or any button of another radio remote control, to the same function, repeating the operations from point 3.</p>	





### 4.5.2 - Deletion of a memorised button of a radio remote control

<p>Exit any menu, press and hold the button <b>⊖</b> (DOWN-RADIO) until the display shows alternatively, <b>RADIO MENU</b>.</p>	
<p>1. Press and hold the button <b>⊖</b> (DOWN-RADIO) until the KEY LED lights up; release the button.</p>	
<p>2. Within seven seconds, press and hold the button of the radio remote control to be deleted from the receiver's memory until the KEY LED starts flashing; release the button.</p>	
<p>3. Confirm deletion of the radio remote control by pressing the button <b>⊖</b> (DOWN-RADIO)</p>	
<p>4. A long flash of the KEY LED indicates that the radio remote control has been deleted.</p>	
<p>5. The control unit exits the <b>RADIO MENU</b> after seven seconds of inactivity or by briefly pressing the button <b>Ⓜ</b> (MENU)</p>	
<p>If the transmitter you wish to delete was originally memorized using the <b>LEARN ALL</b> output (see paragraph 4.5.1, point 2), the deletion procedure mentioned above will delete all the functions associated with the buttons of that transmitter.</p>	

#### 4.5.3 - Deletion of the entire receiver memory

Exit any menu, press and hold the  (DOWN-RADIO) button until the display alternately shows RADIO MENU.	 
1. Press and hold down the  (DOWN-RADIO) button until the KEY LED lights up (approximately three seconds); keep the button  (DOWN-RADIO) pressed until the KEY LED turns off; release the button.	   
2. After releasing the button the KEY LED starts to flash slowly; count the flashes.	   
3. At the third flash, briefly press the button  (DOWN-RADIO).	
4. A long flash of the KEY LED indicates that all the radio remote controls have been deleted.	 
5. The control unit exits the RADIO MENU after seven seconds of inactivity or by briefly pressing the button  (MENU)	









#### 4.5.4 - Memorisation of a button of a new radio remote control using a radio remote control already saved in memory

It is possible to add the button of a new radio remote control to a control unit in which at least one radio remote control has already been memorised	
1. Near the control unit, press and hold the button of the new radio remote control to be added to the control unit for at least five seconds	 (5s)
2. Near the control unit, press and hold down for at least three seconds the button of the already memorised radio remote control to which the function to be duplicated on the new radio remote control is associated. <b>NOTE:</b> if step 1. has been correctly performed, the automation does not perform any manoeuvre and it is possible to proceed with memorisation.	 (3s)
3. Near the control unit, press and hold the same button on the new radio remote control used in point 1 for at least three seconds.	 (3s)
4. Near the control unit, press and hold the same button on the old radio remote control used in point 2 for at least three seconds. <b>NOTE:</b> the procedure has been correctly performed if the automation executes the command just memorised.	 (3s)
If the procedure is not completed, after a few seconds the control panel receiver returns to normal operation.	

#### 4.6 - Factory parameters reset

To return all the parameters to their default values or to change the type of equipment on which the control panel is installed, proceed as follows:

**⚠ WARNING !** If the motor type is not changed, the following procedure restores the default values and it is not necessary to re-learn the stroke.

- Press and hold the button  (MENU); the display shows in sequence BASE ADV; release the button near the text ADV.
- Scroll through the menu items with the buttons  (UP) and  (DOWN-RADIO) until reaching MOTOR SETUP
- Press and hold the button  (MENU); release the button when the display starts flashing; the number displayed indicates the type of motor in use.
- Select with the buttons  (UP) and  (DOWN-RADIO) the type of motor; press and hold the button  (MENU). The display shows a countdown from 50 to 0; release the button when the text DONE appears.
- The control unit exits the MENU after seven seconds of inactivity or by briefly pressing the  (MENU) button.

**⚠ WARNING !** If the type of motor is changed, all the values are returned to the factory value and it is necessary to perform a new auto-learning procedure for the travel.

## 5 - SYSTEM CUSTOMISATION

The configuration menus of the equipment operating functions are divided into BASE and ADV (basic/advanced). The following tables show the description of each basic parameter with the respective minimum, maximum and default values.

1. Press and hold the button **M** (MENU); the display shows in sequence **BASE** and **ADV**, release the button at the wording **BASE** to access the basic menu.
2. Scroll through the menu items with the buttons **+** (UP) and **-** (DOWN-RADIO) until reaching the desired parameter
3. Press and hold the button **M** (MENU) until the display flashes; release the button **M** (MENU)
4. To change the value, use the buttons **+** (UP) and **-** (DOWN-RADIO); to confirm the new value press and hold the button **M** (MENU) until the display stops flashing
5. To exit the menu, briefly press the button **M** (MENU)

**NOTE:** to view the value of any parameter simply enter the relevant menu (BASE or ADV) using steps 1 and 2 of the procedure just described. Once the desired parameter has been identified, the display alternately shows the name of the parameter and the value. To exit the menu, briefly press the button **M** (MENU)

### 5.1 - Basic Parameters

PARAMETERS	DESCRIPTION	DEFAULT	MIN	MAX	UNIT
1 <b>AUTO</b> <b>CLOSE</b>	Automatic re-closing time (0 = off)	0	0	900	s
2 <b>PHOTO</b> <b>CLOSE</b>	Re-closing time after the transit on PH1 (0 = off)	0	0	30	s
3 <b>REROT</b> <b>TIME</b>	Force on obstacles 0 = Maximum impact force 10 = Minimum impact force	3	0	10	
4 <b>OPEN</b> <b>SPEED</b>	Motor speed in opening 1 = minimum 2 = low 3 = medium 4 = high 5 = maximum	4	1	5	
5 <b>SLOW</b> <b>OP</b> <b>SPEED</b>	Motor speed in opening during the slowing down phase. 1 = minimum 2 = low 3 = medium 4 = high 5 = maximum	1	1	5	
6 <b>CLOSE</b> <b>SPEED</b>	Motor speed in closing 1 = minimum 2 = low 3 = medium 4 = high 5 = maximum	4	1	5	
7 <b>SLOW</b> <b>CL</b> <b>SPEED</b>	Motor speed in closing during the slowing down phase. 1 = minimum 2 = low 3 = medium 4 = high 5 = maximum	1	1	5	
8 <b>SBS</b> <b>SETUP</b>	STEP-By-STEP or SBS configuration: 0 = Normal (-ST-CH-ST-AP-ST...) 1 = Alternate (-ST-CH-AP-ST-CH...) 2 = Alternate (AP-CH-AP-CH...) 3 = Condominium – timer (set <b>AUTO</b> <b>CLOSE</b> ≠ 0) 4 = Condominium with immediate re-closing	0	0	4	

9	STOP TWO	<p>Additional insertion/additional edge:  0 = disabled  1 = the PAR input becomes STOP NO  2 = the PAR input becomes STOP NC  3 = the PAR input becomes EDGE NC on opening  4 = the PAR input becomes EDGE 8K2 on opening  5 = the PAR input becomes EDGE 4K1 on opening</p> <p><b>⚠ WARNING !</b> to activate EDGE2, the TYPE EDGE parameter must be 0 (EDGE1 only on closing)</p> <p><b>⚠ WARNING !</b> EDGE2 is connected as "Opening Edge" and will be considered if it is engaged during the opening. It will react with a short gate reverse to clear the obstacle.</p> <p><b>⚠ WARNING !</b> deactivation of the safety with DIP SWITCH has no effect on this input.</p>	0	0	5	
10	LENGH SLOW	<p>Slowdown amplitude  P = customised by learning  From 1 to 100 = Percentage of slowdown in closing and opening of the motors</p>	20	1	100	%
11	BLACKOUT	<p>Behaviour after power failure  0 = no action, it remains as it is  1 = Closure</p>	0	0	1	
12	STANDBY	<p>Energy saving: enabling to turn off the photocells when the gate is closed (only during this function the PHOTOTEST is not possible)  0= disabled  1= enabled</p>	0	0	1	

## 5.2 - Advanced Parameters

The ADVANCED MENU allows the system to be further customised by modifying parameters not accessible from the basic menu. **To access the ADVANCED menu, press the MENU key and hold it down for 5 seconds.**

To modify ADVANCED MENU parameters, proceed as described for the BASIC MENU.

**NOTE: Some default functions/displays may vary depending on the type of motor selected.**

PARAMETERS	DESCRIPTION	DEFAULT	MIN	MAX	UNIT
1 PHOTO SETUP	<p>PHOTO1 behaviour when starting from closed  0 = Check PHOTO1  1 = The gate opens even with PHOTO1 engaged</p>	1	0	1	
2 PHOTO2 SETUP	<p>Use of PHOTO2:  0 = Enabled both during opening and closing  1 = Enabled only during opening  2 = If it exceeds, it turns on the courtesy light for a time set by the "TIME LIGHT" parameter (sliding door only)</p>	1	0	2	
3 PHOTOTEST	<p>Photocell functionality test:  0 = off  1 = PHOTO1 on  2 = PHOTO2 on  3 = PHOTO1 and PHOTO2 on</p>	0	0	3	
4 TYPE EDGE	<p>STOP/EDGE input selection:  0 = STOP contact (NC)  1 = Resistive safety edge (8k2)  2 = Safety contact edge (NC)  3 = Double resistive safety edge (4k1)  When an edge is activated, the automation performs a brief reversal and then stops.</p>	1	0	3	

5	SETUPEDGE	0 = EDGE1 intervenes only during closing with a short reversal 1 = EDGE1 intervenes during both closing and opening with a short reversal Attention: if the PAR input is used as EDGE2 then SETUPEDGE must be 0	0	0	1	
6	TESTEDGE	Edge test 0 = disabled 1 = enabled	0	0	1	
7	SETUPPART	Partial opening	50	0	100	%
8	CLOSEPART	Partial automation re-closing time (0 = disabled)	0	0	900	s
9	FLASHSETUP	Flashing light output setup 0 = Steady 1 = Flashing	1	0	5	
10	PRESETUP	Pre-flash behaviour (disabled if PRETIME=0) 0=before an opening or closing manoeuvre 1=before a closing manoeuvre 2=before an opening manoeuvre	0	0	2	
11	PRETIME	Pre-flash time (0 = disabled)	0	0	20	s
12	SETUPLIGHT	Courtesy light configuration 0 = At the end of the manoeuvre turned on for time TIMELIGHT 1 = On if gate not closed + duration TIMELIGHT 2 = On if courtesy light time TIMELIGHT not expired	0	0	2	
13	TIMELIGHT	Courtesy light duration time	0	0	900	s
14	CLEARANCE	Clearance. Used to stop before the completely open position: it is useful to avoid mechanical stress during opening. <b>⚠ WARNING !</b> This parameter is only available for swing doors.	0	0	30	%
15	WINDREACT	If the door is closed and something tries to open it, the door reacts by trying to close. Useful if a strong wind could open the door. 0 = disable 1 = enable <b>⚠ WARNING !</b> This parameter is not available for swing doors.	0	0	1	
16	HOLDTORUN	Hold-to-run 0 = off 1 = on	0	0	1	
17	INDICLIGHT	0 = disabled 1 = open gate light ON/OFF 2 = proportional open gate light - Slow flashing when the gate opens - Quick flashing when the gate closes - Steady light if the gate is open - 2 flashes + pause with the gate stopped (position other than closed) 3 = Electric lock 4 = Magnetic electric lock function with active output when the gate/door is closed (interface with external relay with 24 Vdc winding)	0	0	4	
18	CYCLESERVI	Service Interval Cycle Interval (0 = Off)	10	0	200	x 1000 cycles



19	SETUPSERVI	Enabling of continuous flashing for assistance request with SERVICE CYCLE ≠ 0 (function only performed when the gate is closed). 0 = disabled 1 = enabled	0	0	1	
20	ELECTTIME	Electric lock activation time if the electric lock is activated. Deactivation time of the magnetic electric lock if the magnetic lock is selected.	4	1	10	s
21	BOOSTSETUP	High speed motor start 0 = disabled 1 = activated	0	0	1	
22	ENCODSETUP	Shows the type of encoder in use 0 = disabled (virtual encoder) 1 = activated (physical encoder)	0	0	1	
23	MOTORSETUP	Determines the type of automation on which the control unit is installed: 0 = Reset to factory settings for TU4324/TUS4324 sliding motor 1 = Factory reset for SUN5324 sliding motor 2 = Factory reset for sliding motor SUN7324, TU7324/TUS7324 3 = Factory reset for sliding motor SUN11324M, TU11324/TUS11324 4 = Restore factory settings for 4/6 m barrier (see the user manual for the barrier) 5 = Restore factory settings for 8 m barrier (see the user manual for the barrier) 6 = Restore factory settings for overhead door	1	0	6	

## 6 - TESTING AND COMMISSIONING THE AUTOMATION SYSTEM

The system must be tested by a qualified technician, who must perform the tests required by the relevant standards in relation to the risks present, to check that the installation complies with the

relevant regulatory requirements, especially the EN 12453 standard which specifies the test methods for gate and door automation systems.

### 6.1 - Testing

All system components must be tested following the procedures described in their respective operator's manuals;  
ensure that the recommendations in Chapter 1 - Safety Warnings - have been complied with;  
check that the gate or door is able to move freely once the automation system has been released and is well balanced, meaning that it will remain stationary when released in any position;  
check that all connected devices (photocells, safety edges, emer-

gency buttons, etc.) are operating correctly by performing gate or door opening, closing and stop tests using the connected control devices (transmitters, buttons or switches);  
perform the impact measurements as required by the EN12453 standard, adjusting the control unit's speed, motor force and deceleration functions if the measurements do not give the required results, until the correct setting is obtained.

### 6.2 - Commissioning

Once all (and not just some) of the system devices have passed the testing procedure, the system can be commissioned;  
the system's technical dossier must be produced and kept for 10 years. It must contain the electrical wiring diagram, a drawing or photograph of the system, the analysis of the risks and the solutions adopted to deal with them, the manufacturer's declaration of conformity for all connected devices, the operator's manual for every device and the system maintenance plan;  
fix a dataplate with the details of the automation, the name of the person who commissioned it, the serial number and year of construction and the CE marking on the gate or door;  
also fit a sign specifying the procedure for releasing the system by hand;

draw up the declaration of conformity, the instructions and precautions for use for the end user and the system maintenance plan and consign them to the end user;  
ensure that the user has fully understood how to operate the system in automatic, manual and emergency modes;  
the end user must also be informed in writing about any risks and hazards still present;

**⚠ WARNING !** after detecting an obstacle, the gate or door stops during its opening travel and automatic closure is disabled; to restart operation, the user must press the control button or use the transmitter.

## 7 - INSTRUCTIONS AND WARNINGS FOR THE END USER

Key Automation S.r.l. produces systems for the automation of gates, garage doors, automatic doors, roller blinds and car-park and road barriers. However, Key Automation is not the manufacturer of your complete automation system, which is the outcome of the analysis, assessment, choice of materials and installation work of your chosen installer. Every automation system is unique, and only your installer has the experience and skill required to produce a safe, reliable, durable system tailored to your needs, and above all that complies with the relevant regulatory standards. Although your automation system complies with the regulation safety level, this does not rule out the presence of "residual risk", meaning the possibility that hazards may occur, usually due to reckless or even incorrect use. We would therefore like to give you some advice for the correct use of the system:

- before using the automation system for the first time, have the installer explain the potential causes of residual risks to you;
- keep the manual for future reference, and pass it on to any new owner of the automation system;
- reckless use and misuse of the automation system may make it dangerous: do not operate the automation system with people, animal or objects within its range of action;
- a properly designed automation system has a high level of safety, since its sensor systems prevent it from moving with people or obstacles present so that its operation is always predictable and safe. However, as a precaution children should not be allowed to play close to the automation system, and to prevent involuntary activation, remote controls must not be left within their reach;
- as soon as any system malfunction is noticed, disconnect the electricity supply and perform the manual release procedure. Never attempt repairs on your own; call in your installation engineer. In the meantime the door or gate can be operated without automation once the geared motor has been released using the release key supplied with the system. In the event of safety devices out of service arrange for repairs to the automation immediately;
- in the event of malfunctions or power failures: while waiting for the engineer to come (or for the power to be restored if your system is not equipped with buffer batteries), the door or gate can be used just like any non-automated installation. To do this, the manual release procedure must be carried out;
- manual release and operation: first bear in mind that the release procedure can only be carried out with the door or gate stationary.
- Maintenance: Like any machine, your automation system needs regular periodic maintenance to ensure its long life and total safety. Arrange a periodic maintenance schedule with your installation engineer. Key Automation recommends that maintenance checks should be carried out every six months for normal domestic use, but this interval may vary depending on the level of use. Any inspection, maintenance or repair work must only be carried out by qualified staff.
- Never modify the automation system or its programming and setup parameters: this is the responsibility of your installation engineer.
- Testing, routine maintenance and any repairs must be recorded by the person who performs them and the documents must be conserved by the system's owner.

The only procedures you are capable of, and which you are recommended to perform, are cleaning of the photocell glass and removal of any leaves or stones that may obstruct the automation system. To prevent anyone from activating the gate or door, release the automation system before starting. Clean only with a cloth dipped in

a little water.

At the end of its useful life, the automation system must be dismantled by qualified personnel, and the materials must be recycled or disposed of in compliance with the legislation locally in force.

If after some time your remote control seems to have become less effective, or stops operating completely, the battery may be flat (depending on the level of use, this may take from several months up to more than a year). You will realise this because the transmission confirmation light does not come on, or only lights up for a very short time.

Batteries contain pollutants: do not dispose of them with normal waste but follow the methods specified by the local regulations.

Thank you for choosing Key Automation S.r.l.; please visit our Internet site [www.keyautomation.com](http://www.keyautomation.com) for further information.

# DICHIARAZIONE DI INCORPORAZIONE DI QUASI MACCHINA

## DECLARATION OF INCORPORATION OF PARTLY COMPLETED MACHINERY

Il sottoscritto Nicola Michelin, Amministratore Delegato dell'azienda  
*The undersigned Nicola Michelin, General Manager of the company*

Key Automation s.r.l., via Meucci 23, 30027 San Donà di Piave (VE) – ITALIA

dichiara che il prodotto tipo:  
*declares that the product type:*

### CT10324

Centrale di comando per cancelli/barriere a 1 motore 24Vdc, con ricevente 433,92 MHz integrata  
*Control unit for one 24Vdc gate/barrier automation, with embedded 433,92 MHz receiver*

Models:

*Models:*

900CT10324, 900CT10324F

E' conforme a quanto previsto dalle seguenti direttive comunitarie:  
*Complies with the following community (EC) regulations:*

Direttiva macchine / Machinery Directive 2006/42/EC  
Direttiva compatibilità elettromagnetica / EMC Directive 2014/30/EU  
Direttiva bassa tensione / LVD Directive 2014/35/EU  
Direttiva radiofrequenza / RED Directive 2014/53/EU  
Direttiva RoHS / RoHS Directive 2011/65/EU

Secondo quanto previsto dalle seguenti norme armonizzate:  
*In accordance with the following harmonized standards regulations:*

EN IEC 55014-1:2021, EN IEC 55014-2:2021  
EN 60335-1:2012+A15:2021, EN 60335-2-103:2015  
EN IEC 61000-3-2:2019, IEC 61000-3-3:2013 + A2:2021  
EN IEC 61000-6-1:2019, EN IEC 61000-6-3:2021  
EN ISO 13849-1:2015, EN ISO 13849-2:2012  
EN 12453:2017 + A1:2021  
ETSI EN 301 489-1 V2.2.3:2019, ETSI EN 301 489 V2.3.2:2023  
EN 62233:2008

Dichiara che la documentazione tecnica pertinente al prodotto è stata redatta conformemente a quanto previsto dalla direttiva 2006/42/CE Allegato VII parte B e verrà fornita a fronte di una richiesta adeguatamente motivata dalle autorità nazionali.  
*Declares that the technical documentation is compiled in accordance with the directive 2006/42/EC Annex VII part B and will be transmitted in response to a reasoned request by the national authorities.*

Dichiara altresì che non è consentita la messa in servizio del prodotto finché la macchina, in cui il prodotto è incorporato, non sia stata dichiarata conforme alla direttiva 2006/42/CE.  
*He also declares that is not allowed to use the above mentioned product until the machine, in which this product is incorporated, has been identified and declared in conformity with the regulation 2006/42/EC.*

San Donà di Piave (VE), 08/11/23

Amministratore Delegato  
General Manager  
Nicola Michelin



Key Automation S.r.l.  
Via Meucci 23  
30027 San Donà di Piave (VE)  
P.IVA 03627650264 C.F. 03627650264  
[info@keyautomation.it](mailto:info@keyautomation.it)

Capitale sociale 154.000 € i.v.  
Reg. Imprese di Venezia 03627650264  
REA VE 326953  
<http://www.keyautomation.com/>



Organizzazione con sistema di gestione certificato

**Key Automation S.r.l.**

Via Meucci 23 - 30027 San Donà di Piave (VE)

T. +39 0421 307456 - [info@keyautomation.it](mailto:info@keyautomation.it)

[www.keyautomation.com](http://www.keyautomation.com)

Instruction version  
580CT10324 REV03